

## ASSESSMENT OF SOME WATERBORNE FINISHES FOR WOOD EXPOSED TO NATURAL WEATHERING TEST

**Amalia Gabriela NIȚURA**

Transilvania University of Brasov, Faculty of Furniture Design and Wood Engineering  
Address: Str. Universitatii nr. 1, 500068 Brasov, Romania  
E-mail: [amalia.gabryela@yahoo.com](mailto:amalia.gabryela@yahoo.com)

**Emanuela Carmen BELDEAN**

Transilvania University of Brasov, Faculty of Furniture Design and Wood Engineering  
Address: Str. Universitatii nr. 1, 500068 Brasov, Romania  
E-mail: [ebeldean@unitbv.ro](mailto:ebeldean@unitbv.ro)

### Abstract:

*This study assesses the durability of waterborne finishing systems applied to pine (*Pinus sylvestris*), spruce (*Picea abies*), and oak (*Quercus robur*) after six months of natural weathering. Three finishing systems were tested: primer, primer and varnish (transparent), and primer and enamel (opaque), according to SR EN 927-3:2019. Visual inspection, CIELab measurements, and stereomicroscopic analysis of the surface revealed that the opaque enamel provided the best protection after 6 months of weathering ( $\Delta E = 4.7\text{--}5.5$ ), with no visible biological deterioration. Primer-only coatings exhibited the highest colour change ( $\Delta E$  up to 18.1), depending on the wood species. Oak was more stable in colour than pine and spruce, but all species had a yellowing tendency after exposure. A slight discoloration was visible on the surface of the transparent coatings. The colour of the uncoated samples was significantly different, highlighting the wood's vulnerability to environmental exposure and emphasizing the need for appropriate finishing for outdoor use.*

**Key words:** waterborne coatings; natural weathering; colour stability; biological degradation; wood species.

### INTRODUCTION

Wood, as a natural and renewable resource, is increasingly preferred for various applications and requires suitable surface protection to enhance durability when exposed to outdoor factors. Weathering is a complex phenomenon characterized by both physical and chemical degradation of wood. Outdoor factors such as moisture, solar radiation, temperature fluctuations, oxygen, and pollutants pose significant threats to wooden surfaces (Feist 1990). These elements can lead to considerable deterioration, affecting not only the wood itself but also its protective coatings, resulting in issues such as photodegradation, which alters the chemical composition of the wood, surface cracking, peeling of the protective film, loss of gloss, and biological deterioration. However, the weathering process can be mitigated or even halted through appropriate treatments and finishes.

Numerous studies focused on the performance of exterior finishes applied on different wood species as oak, Scots pine, alder, Douglas fir, tropical species (De Windt et al. 2014, Cailleux 2016, Oberhofnerova et al. 2019, Podgorski et al. 2019, Davis et al. 2021, Dvořak et al. 2023, Podgorski 2023) or concluded that technological procedures and coating formulations can significantly increase the quality of the coated surfaces (Laleicke and Hubbe 2025).

In the context of reducing the impact on the environment and compliance with European directives on volatile organic compounds (VOCs), waterborne finishing products represent an increasingly relevant alternative for outdoor wood finishing (Laleicke and Hubbe 2025).

One of the methods used for testing wood finishes is the norm EN 927-3:2019 - *Paints and varnishes - Coating systems for exterior wood - Part 3: Natural weathering test*, which defines the methodology for evaluating the behaviour of protective coatings under natural outdoor conditions (Dawson and Göttgens 2005). This standard regulates the natural exposure of coated wood panels and provides a rigorous framework for assessing decorative and protective finishes in terms of resistance to weathering, colour stability, coating integrity, and defect occurrence (cracks, flaking, blistering).

To our knowledge, no studies have been conducted in Romania in accordance with this standard, and interest in wooden buildings and their protection is continuously growing (<https://asfor.ro/2025/02/23/utilizarea-lemnului-in-constructiile-publice>). Furthermore, while solvent-based finishes are still widely used, water-based finishes are becoming more popular.

### OBJECTIVES

The main objective of the paper was to assess the performance of waterborne protective and finishing systems applied to three wood species commonly used outdoors (pine, spruce, and oak), in accordance with SR EN 927-3:2019, and to monitor the colour changes, coating defects, and biological degradation. The

research also aimed to determine the influence of wood species on coating performance and to observe the evolution of degradation during two and six months of exposure.

## MATERIAL AND METHODS

### Wood selection

In this study, three wood species commonly used in practice were selected for testing: Pine (*Pinus sylvestris*), Spruce (*Picea abies*), and Oak (*Quercus robur*). Pine was chosen as the reference substrate following the requirements of EN 927-3:2019, which provides European pine sapwood as the mandatory wood type for natural weathering tests. Spruce and oak were chosen due to their wide use in exterior applications and their representative anatomical and physical properties, which may influence the adhesion and durability of coatings.

A total of 48 wood panels were prepared, 16 from each species: Pine, Spruce, and Oak. The panels were cut to dimensions of 375 × 78 × 20 mm (longitudinal × tangential × radial) (Fig. 1), free from visible defects, and with uniform grain orientation. After preparation, the panels were stored in the laboratory and conditioned at 20 ± 2°C and 65 ± 5% relative humidity until they reached a constant weight.

The same conditions were maintained after finishing. Panels were randomly assigned to the different coatings and treatments. Three replicates for each treatment and species were used.

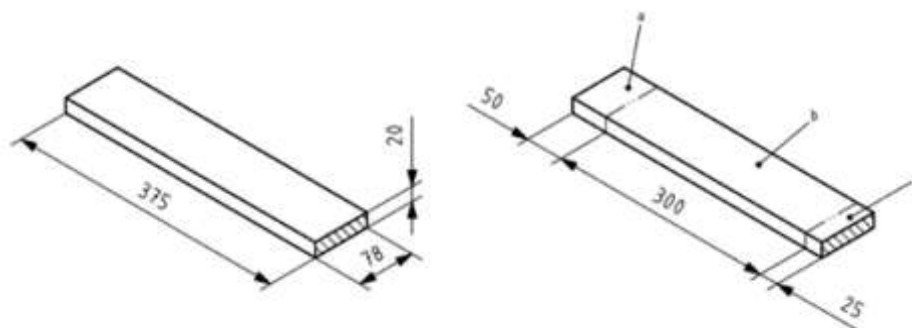

Fig. 1.

**Sample Dimensioning According to EN 927-3:2019 (a-sealed end; b-section for application of coating system, c-sealed end).**

### Coating systems

The coatings used in this study were commercial waterborne acrylic products, including primer, varnish, and enamel. The primer, which contains biocidal agents to prevent fungal attack, was applied as a first layer to improve adhesion and prepare the wood surface for subsequent layers. Varnish provided a transparent protective coating, enhancing gloss and durability, while enamel offered an opaque decorative and protective finish. According to the manufacturer, the varnish and enamel were formulated with UV protection additives to minimize colour changes and film degradation caused by solar radiation during outdoor exposure.

All coatings were applied according to the manufacturer's instructions, using a brush, and panels were allowed to dry under controlled laboratory conditions (20 ± 2°C and 65 ± 5% relative humidity) between coats. The number of layers and the approximate film thickness per layer were recorded to ensure uniformity among samples.

For each coating system, a primer layer was first applied. Coatings were applied by brushing to the front face and the two edges of each panel, leaving the back and both ends uncoated.

Before exposure, the theoretical dry film thickness was calculated based on the product data sheet, using the following formula:

$$g_p = C_{sp} \cdot \frac{C_{su}}{100} [\mu\text{m}] \quad (1)$$

where:  $g_p$  = dry film thickness [ $\mu\text{m}$ ];

$C_{sp}$  = coating application rate [ $\text{g}/\text{m}^2$ ]

$C_{su}$  = content of non-volatile substances [%] (from the technical data sheet)

The finishing systems for wood samples are presented in Table 1.

Table 1

Characteristics of products and specifications for the application

Coating system Code	Number of layers		Properties given by the producer	Technological parameters	
				Spreading rate, g/m <sup>2</sup>	Theoretical film thickness, μm
Primer /G	1	0	waterborne; biocide	100	20
Primer+ varnish/ GL	1	2	transparent; semigloss	80	72.8
Primer+ enamel/ E	1	2	waterborne; UV protection; opaque; matte appearance	76-80	98 The first layer was diluted with 5% water

Once the coatings were dried, the panel ends were sealed using a D4 polyurethane adhesive, moisture-resistant according to EN 927-3:2000. After sealing, the panels were conditioned for seven days under controlled conditions at 20°C and 65% relative humidity.

**Weathering exposure**

The natural weathering exposure of the samples was carried out in accordance with SR EN 927-3:2019. Out of the total 48 samples, 16 from each species were exposed outdoors, while 9 reference samples were kept indoors, protected from light.

The test racks were mounted at a 45° angle to the horizontal and oriented to the south, as required by the standard. They were arranged so that the long edge of each panel was positioned horizontally, and the 50 mm marking area was consistently placed on the same side, ensuring uniform exposure conditions for all specimens (Figure 2a).



a

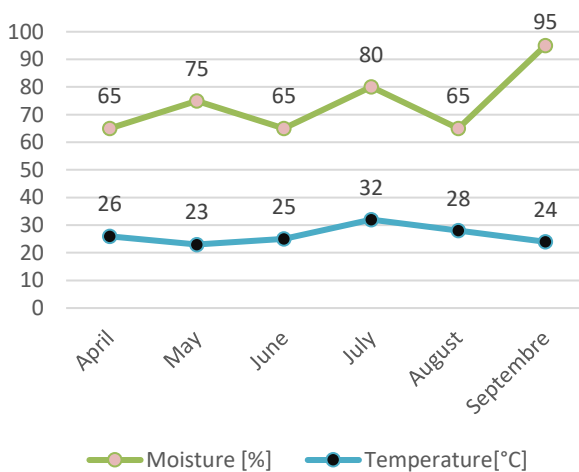

b

**Fig. 2.**  
**Outdoor Exposure Rack according to EN 927-3:2019 (a); Meteorological data for the exposure site (coordinates: 45°39'N, 25°35'E) during the study (b).**

**Climatic conditions monitoring**

Between April and September 2025, samples were exposed to temperatures ranging from 10-32 °C and relative humidity between 35-95%. Rainfall was generally moderate, with substantial episodes at the end of May and after August 20. During June-August, temperatures frequently exceeded 25 °C, while in September they gradually decreased. These climatic conditions promoted coating degradation through UV radiation, high humidity, and localised mould growth.

The meteorological conditions at the exposure site were monitored and are presented in Figure 2 b (data obtained from Meteoblue.com).

**Colour measurements by the standardised CIELab system**

Before exposure, film thickness was verified by non-destructive methods (EN ISO 2808), and initial colour was visually evaluated by photo-scanning and also measured in CIELab system using a UV-VIS AvaSpec-USB2 spectrophotometer equipped with an integrating AVA sphere of 8 mm, under standard illuminant D65 and 2° standard observer. Data were processed with AVASOFT version 7.7. Six distinct measurement points were measured on each of 36 samples. The average values of each colour parameter (L\*, a\*, b\*) were used for comparative analysis between the initial and post-exposure conditions and for calculating the total colour difference ( $\Delta E^*$ ).

The colour differences ( $\Delta E$ ) were calculated using the following equation:

$$\Delta E^* = \sqrt{(\Delta L^*{}^2 + \Delta a^*{}^2 + \Delta b^*{}^2)} \tag{2}$$

where:  $\Delta L^*$  – difference in lightness between the initial and final states;

$\Delta a^*$  – difference in the red–green coordinate;

$\Delta b^*$  – difference in the yellow–blue coordinate;

$\Delta E^*$  – total colour difference, expressing the overall variation in colour perception between the two states.

Colour measurements were carried out two months after the beginning of exposure and repeated after 6 months of exposure to monitor the changes in appearance (colour change, cracks, biological defects). Results were compared with initial values, and the samples were returned to the stand for further intermediary assessments and a final evaluation after 12 months of exposure. Thus, the colour stability of the tested finishing systems was determined.

**Microscopic investigation**

The samples exposed were investigated on the surface using a Nikon SMZ18 stereomicroscope at magnifications of 22.5-90x. The camera and NIS Elements Software captured images of high quality on wood discoloration. Also, the film thickness was measured.

**RESULTS**





**Visual analysis and colour changes**





















A comparative visual analysis of the wood surface appearance was carried out before and after natural exposure, over two and six months. Samples corresponding to each treatment variant were documented by photo-scanning: uncoated wood, wood only coated with primer, wood coated with primer and varnish, and wood coated with primer and enamel. The evaluation focused on identifying aesthetic, physical, and biological changes resulting from exposure to environmental factors such as UV radiation, humidity, precipitation, temperature fluctuations and biological occurrence. In Table 2, the general aspect of the samples after 6 months of exposure is presented compared with unexposed samples.

The exposed samples are darker in colour, showing some discoloration. Additionally, a noticeable yellowing of transparent finishes is evident. No visible changes were identified in opaque coatings.

Table 2

**Visual appearance of the samples exposed after 6 months of weathering, compared with the unexposed, revealing the coating system**

Wood		No treatment	Primer G	Primer + varnish GL	Primer + Enamel E
<b>PINE</b>	Unexposed				

	Exposed				
<b>SPRUCE</b>	Unexposed				
	Exposed				
<b>OAK</b>	Unexposed				
	Exposed				

All samples exhibited a darkening of colour following exposure, in the CIELab system, as shown in Figure 3. Coated samples with white enamel demonstrated the least variation in lightness for all three species. Compared to unfinished samples, the transparent coatings: primer, primer and varnish showed a slightly darker colour after two months. Oak wood showed a decrease in the  $L^*$  parameter for coated samples compared with uncoated ones. After six months, the  $L^*$  values of the coated samples increased slightly. Among the wood types assessed, oak exhibited the smallest change in brightness relative to pine and spruce.

The darkening of the samples may be linked to the beginning of biological discoloration, indicated in Figure 5. The positive  $b^*$  parameter reflects an increase in yellowness after two months, visible on the samples in Table 2, but decreased after six months for all samples except those finished with enamel. A similar trend was observed for the redness parameter,  $a^*$ .

Nevertheless, the variation in colour parameters between two and six months of exposure is not very significant. The four months interval between evaluations was probably too short to detect notable changes.

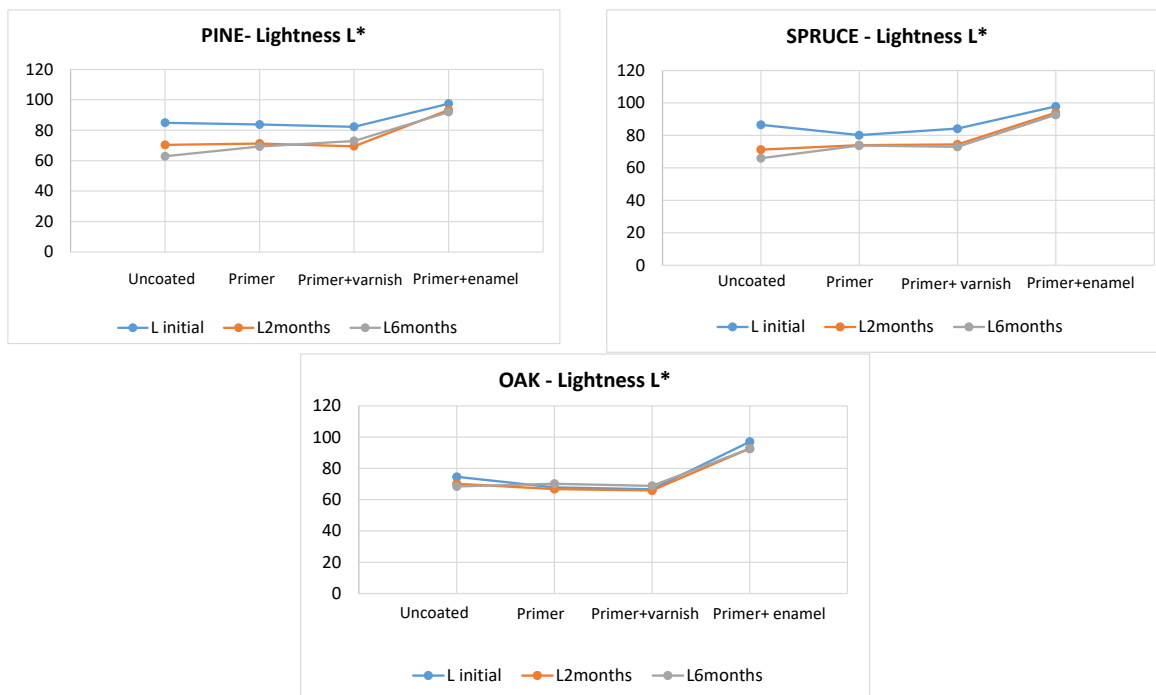

**Fig.3.**  
**The evolution of the L\* colour parameter during 2 and 6 months of exposure for uncoated and coated samples.**

The colour variation ( $\Delta E$ ) calculated as average values (with standard deviations) reached values up to 28.1 for unfinished samples and up to 18.1 for finished samples, depending on the wood species and coating system (Table 3).

Table 3

**Average Colour Difference After 2 and 6 Months of Exposure**

Coating	Wood	Colour change, $\Delta E$ (stdev)										
		Initial			After 2 months				After 6 months			
		L	a	b	L2	a2	b2	$\Delta E$	L6	a6	b6	$\Delta E$
Primer	Pine	83.8	2.6	21.7	71.3	6.7	21.7	13.6 (2.40)	69.3	4.3	11.6	18.1 (5.87)
Primer	Spruce	80.2	4.3	20.0	74.0	6.5	23.1	8.5 (3.99)	73.8	3.4	9.9	12.9 (2.37)
Primer	Oak	67.9	6.9	20.6	66.8	6.0	23.1	4.4 (2.32)	70.2	3.6	11.2	10.8 (2.64)
Primer+varnish	Pine	82.3	3.6	21.1	69.5	7.3	26.5	14.6 (2.49)	73.0	6.3	16.7	11.1 (4.10)
Primer+varnish	Spruce	84.2	2.7	19.5	74.5	6.2	31.4	15.9 (2.96)	73.0	7.8	23.3	13.2 (2.27)
Primer+varnish	Oak	66.7	6.8	19.4	65.9	6.8	26.9	8.1 (2.61)	68.9	6.2	16.4	5.1 (2.87)
Primer+enamel	Pine	97.5	0.1	-2.1	93.3	0.1	-0.3	4.6 (1.65)	91.9	0.1	-0.5	5.5 (0.63)

Primer+ enamel	Spruce	97.9	0.0	-1.7	94.0	0.0	-0.5	4.3 (2.23)	92.7	0.0	-0.4	5.4 (0.58)
Primer+ enamel	Oak	97.1	0.2	-1.7	92.8	0.2	-0.5	4.9 (3.16)	92.7	0.2	-0.4	4.7 (0.68)
Uncoated	Pine	84.9	4.3	23.4	70.4	6.8	24.1	15.7 (3.44)	62.9	1.5	6.7	28.1 (5.78)
Uncoated	Spruce	86.6	3.1	17.0	71.3	6.5	22.0	17.0 (4.48)	66.0	3.0	9.0	22.3 (3.80)
Uncoated	Oak	74.6	6.1	18.2	70.2	5.2	18.5	5.4 (1.73)	68.5	2.1	9.2	12.1 (2.77)

Resinous species, pine and spruce, registered greater colour changes than oak (pine>spruce>oak), except the samples treated with primer and coated with varnish, where spruce wood registered a colour change of 13.2 compared with 11.1 for pine.

The evolution of total colour difference ( $\Delta E$ ) over the two exposure intervals shows distinct behaviours depending on the coating system (see Table 3). The uncoated wood exhibited a total colour change of up to 28.1, while the enamel-coated wood showed values ranging from 4.7 to 5.5. This indicates a medium level of colour change and demonstrates the effectiveness of the opaque finish containing UV-protective pigments. In contrast, the varnish-coated variant is less resistant to colour changes after the test periods due to its lower content of UV absorbers. Additionally, the variant with primer is also less resistant to colour variation; however, it was formulated for biological preservation of the wood, not for UV protection.

Though when comparing coated wood with uncoated wood, a difference in colour resistance can be observed (Figure 4).

The primer exhibits a biotic effect, slightly reducing surface discoloration. The varnish coating improves colour change over primer-treated samples, while the enamel indicates better colour stability under natural exposure across various wood species. It should be noted that this effect is maintained as long as the coating remains adherent on the surface.

The tests are in progress and will further assess the effectiveness of the waterborne finishes after 12 months of exposure.

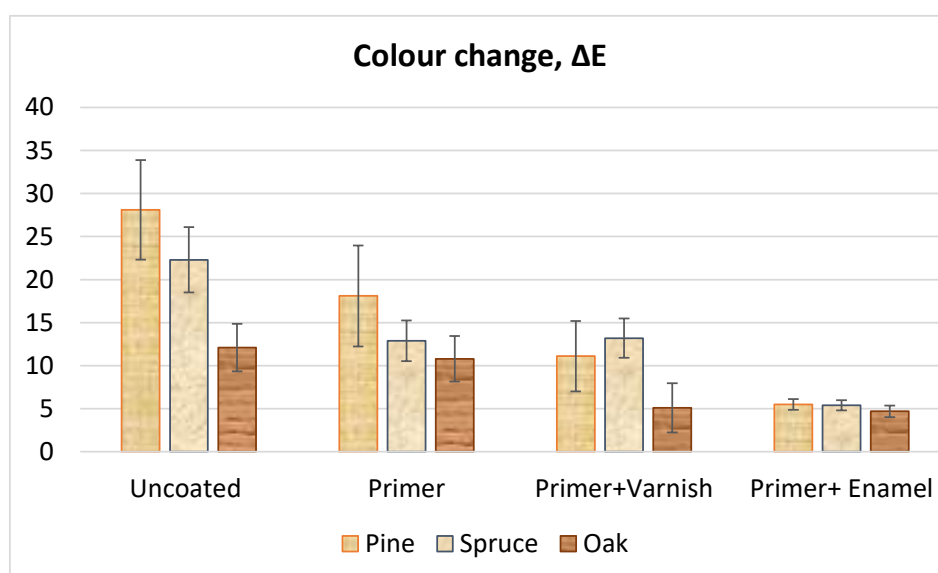

**Fig. 4.**

**Colour change after six months of natural weathering, highlighting the influence of the coating system.**

The colour of the uncoated samples was significantly different, highlighting the wood's vulnerability to environmental exposure and emphasizing the need for appropriate finishing for outdoor use.

**Assessment of biological degradations and film defects**

During observations conducted using the stereomicroscope, the development or extension of cracks after six months of natural exposure was investigated. The appearance of stains and mould was visible on several pine samples, primarily on the untreated ones, but also on those treated only with primer (Figure 5).



**Fig. 5.**

**Mould development on primer-treated wood after six months of natural exposure: (a) pine (*Pinus sylvestris*), (b) oak (*Quercus robur*) (magnification 22.5x).**

Oak samples treated with primer showed more cracks and discoloration. In contrast, samples treated with primer and varnish, as well as those treated with primer and enamel, showed no visible degradation, exhibiting only minor discoloration. All untreated samples, as well as spruce and oak samples, exhibited multiple signs of biological degradation and mould (Figure 6).

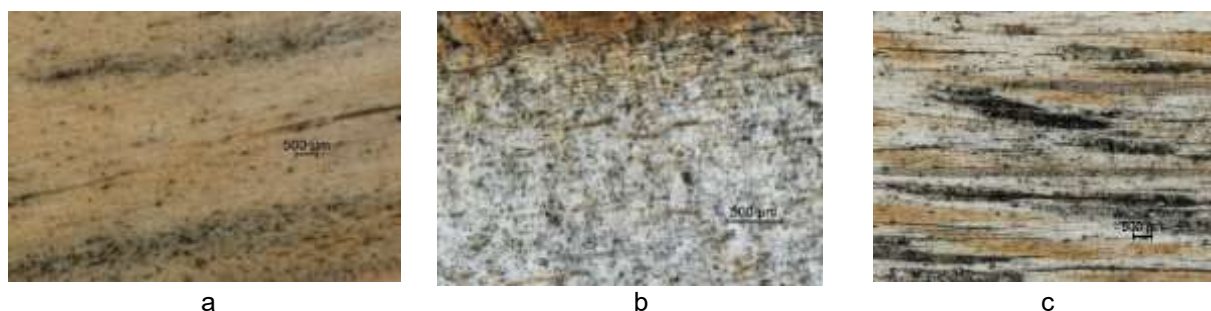

**Fig. 6.**

**Mould development on untreated wood after six months of natural exposure: (a) pine- magnification 22.5x (b) spruce- magnification 60x (c) oak – magnification 22.5x**

No occurrence of blistering, flaking, or chalking was observed on the coated wood surfaces. Although slight mould growth was detected on some samples, the average rating did not exceed rate 1 (Table 4). The assessment of mould growth was performed according to the Photographic Rating Scale for Mould Growth provided in Annex C of the EN 927-3:2019 standard. The moulded samples were rated as follows: 1 for pine and spruce, and 0.83 for oak. Samples treated with primer received a rating between 0.5 and 0.66, depending on the wood species. Samples finished with enamel showed no visible biological degradation on the surface (rate 0).

*Table 4*

**Visual Assessment of Surface Degradation: Average Values of Mould Growth**

Coating	Wood	Average	Observation
Primer	Pine	0,66	Black small dots of mould towards the bottom area
Primer	Spruce	0,66	Slight UV degradation and small black mould spots
Primer	Oak	0,5	UV degradation and small black mould dots in the lower area
Primer+ varnish	Pine	0,66	Black mould dots predominantly in late wood
Primer+ varnish	Spruce	0	Light stains/UV degradation
Primer+ varnish	Oak	0,16	Small black mould dots, white/UV spots
No treatment	Pine	1	Black mould dots and UV degradation

No treatment	Spruce	1	UV degradation, wood cracks
No treatment	Oak	0,83	Small black mould dots, black mould areas in the pores

### Film thickness measurements

The coating film thickness was determined for several finishing systems using the same stereomicroscope. Measurements were performed at several random points across the film cross-sections (Figure 7). The findings are presented as follows: the film thickness measured 34.2 µm for the pine sample with primer, exceeded 50 µm for the oak sample with both primer and varnish, and approximately 70 µm for the spruce sample with primer and enamel. Figure 7 illustrates an example of the film thickness measurements with the stereomicroscope.

Compared to the theoretically calculated film, a slight reduction in thickness occurred, possibly due to the wear of the coating film and the permeability of the wood species.



**Fig. 7.**

**Microscopic measurements of coating film thickness in different areas – example of spruce sample finished with primer and enamel (magnification 90x).**

To create an effective wood coating, it is important to consider the properties of both the coating and the wood. This includes understanding how each wood component interacts with the elements in the coating and how these interactions affect the surface properties after exposure to weathering conditions (Nejad and Cooper 2016).

### CONCLUSIONS

After 2 and 6 months of natural weathering, the enamel finish showed the highest colour stability and durability, exhibiting the least colour change across all wood species tested. The primer and varnish system revealed more noticeable colour changes during the first two months, particularly with higher L\* values. However, these colour differences tended to stabilize or decrease after six months, suggesting an initial adjustment period followed by slight stability. In contrast, the primer-only treatments exhibited substantial colour changes, especially on softwoods, indicating limited protection over the same period.

Multi-layer systems with UV protection, such as the primer and varnish and primer and enamel, were significantly more resistant to environmental factors than single-layer primer applications. This highlights the importance of selecting the appropriate coating system for long-term exterior performance. The wood species also had a significant impact: softwoods such as pine and spruce showed greater colour changes compared to oak, confirming that the inherent properties of the wood influence the effectiveness and durability of protective coatings.

No blistering, flaking, or chalking was observed on any coated surfaces, and biological degradation was minimal. Slight mould growth was detected on some samples, with average ratings below 1, while the enamel-coated surface showed no visible biological deterioration, underscoring its superior protective effect.

This study is ongoing and will continue for a minimum of 12 months of natural exposure, in accordance with SR EN 927-3:2019, to fully assess long-term durability, colour stability, and surface degradation. Overall, the results emphasize that combining the appropriate wood species with a carefully selected finishing system is crucial for achieving durable and aesthetically stable outdoor wood performance.

### REFERENCES

Cailleux E (2016) Performances and durability of maintenance coatings for wooden exterior joinery. Conference: PRA's 10th International Wood Coatings Congress, Amsterdam.

Davis K, Leavengood S, Morrell JJ (2021) Performance of Exterior Wood Coatings in Temperate Climates, *Coatings* **2021**, 11, 325. <https://doi.org/10.3390/coatings11030325>

Dawson B SW, Göttgens A (2005) Natural weathering performance of exterior wood coatings on *Pinus sylvestris* and *Pinus radiata* in Germany and New Zealand, *Journal of Coatings Technology and Research*, 2(7):539-546, DOI:10.1007/s11998-005-0013-y

De Windt I, Van Acker J, Van der Bulcke J (2014) Outdoor weathering performance parameters of exterior wood coating systems on tropical hardwood substrates, *European Journal of Wood and Wood Products*, DOI: 10.1007/s00107-014-0779-7.

Dvořák O, Kvietková M S, Šimunková K, Machanec O, Pánek M, Pastierovic F, Lin CF, Jones D (2023) The Influence of the Initial Treatment of Oak Wood on Increasing the Durability of Exterior Transparent Coating Systems. *Polymers* **2023**, 15,3251. <https://doi.org/10.3390/polym15153251>

Feist W (1990) Outdoor Wood Weathering and Protection, Chapter 11. In the Book: Archaeological wood, U.S. Department of Agriculture, Forest Service, Forest Products Laboratory, Madison, WI 53705-2398.

Laleicke PF, Hubbe M (2025) Outdoor wood finishing: A review on making wood resistant to moisture, ultraviolet light and degradation, *BioResources* 20(3):7903-7982. DOI:10.15376/biores.20.3

Nejad M, Cooper P (2017) Exterior Wood Coatings. In the book: Wood in Civil Engineering. DOI:10.5772/67170

Oberhofnerova E, Šimunková K, Dvořák O, Šterbová I, Hiziroglu S, Šedivka P, Pánek M (2019) Comparison of Exterior Coatings Applied to Oak Wood as a Function of Natural and Artificial Weathering Exposure, *Coatings* **2019**, 9, 864; doi:10.3390/coatings9120864

Podgorski L (2023) Towards new performance criteria for exterior wood coating, Reprint from *European Coatings Journal*, 04-2023.

Podgorski L, Reynaud C, Montibus M (2019) Fungal Growth on Coated Wood Exposed Outdoors: Influence of Coating Pigmentation, Cardinal Direction, and Inclination of Wood Surfaces, *Coatings* **2019**, 9, 27; doi:10.3390/coatings9010027.

EN 927-1:2013 - *Paints and varnishes - Coating materials and coating systems for exterior wood - Part 1: Classification and selection.*

EN 927-2:2022 - *Paints and varnishes - Coating materials and coating systems for exterior wood - Part 2: Performance specification.*

EN 927-3:2019 - *Paints and varnishes - Coating materials and coating systems for exterior wood - Part 3: Natural weathering test.*

Weather MeteoBlue platform <https://www.meteoblue.com/en/weather/>

<https://asfor.ro/2025/02/23/utilizarea-lemnului-in-constructiile-publice>